

ONKYO SERVICE MANUAL

CD RECEIVER MODEL CR-305X



Silver models

UDD,UDT	120 V AC,60 Hz
UPP	230 V AC,50 Hz
UGT,UGR	220 - 230 V AC,50/60Hz

SAFETY-RELATED COMPONENT WARNING!!

COMPONENTS IDENTIFIED BY MARK \triangle ON THE SCHEMATIC DIAGRAM AND IN THE PARTS LIST ARE CRITICAL FOR RISK OF FIRE AND ELECTRIC SHOCK. REPLACE THESE COMPONENTS WITH ONKYO PARTS WHOSE PARTS NUMBERS APPEAR AS SHOWN IN THIS MANUAL.

MAKE LEAKAGE-CURRENT OR RESISTANCE MEASUREMENTS TO DETERMINE THAT EXPOSED PARTS ARE ACCEPTABLY INSULATED FORM THE SUPPLY CIRCUIT BEFORE RETURNING THE APPLIANCE TO THE CUSTOMER.



TABLE OF CONTENTS

Specifications	2
Caution on replacement of optical pickup	2
Protection of eyes from laser bam during servicing	3
Service procedures	4
Front panel view	5
Rear panel view	6
Remote controller	7
Microprocessor connection diagram	8
Microprocessor terminal descriptions	9
IC Block diagram and descriptions	10
CD Mechanism exploded view	19
Replacement of optical pickup	21
Chassis exploded view parts list	22
Chassis exploded view	23
Block diagram	25
Wiring view	26
Printed circuit board view parts list	27
Schematic diagram (Amplifier section)	29
Printed circuit board view 1	31
Schematic diagram (CD & Microprocessor section)	33
Printed circuit board view 2	35
Printed circuit board view 3	37
CD Adjustment procedures	39
Clock adjustment procedures	40
Assembling of pad	41
packing view	42

SPECIFICATIONS

AMPLIFIER

Power Output:	2 x 20 watts at 4 ohms 1 kHz DIN 2 x 17 watts at 6 ohms 1 kHz DIN 2 x 15 watts at 8 ohms 1 kHz DIN 2 x 20 watts min, RMS at 4 ohms 1 kHz no more than 1 % THD (FTC rating) 2 x 25 watts at 4 ohms EIAJ
Dynamic Power:	2 x 24 watts at 4 ohms 2 x 18 watts at 8 ohms
Total Harmonic Distortion:	0.2 % at 10 watts output
IM Distortion:	0.2 % at 10 watts output
Damping Factor:	25 at 8 ohms
Sensitivity and Impedance:	TAPE/CDR/MD IN : 150 mV, 50 kohms
Frequency Response:	10 to 50,000 Hz : +0 / -3 dB
Acoustic Presence:	1 40 Hz +6.0 dB 2 80 Hz +7.5 dB 3 40 Hz +10 dB 80 Hz +8.0 dB 4 40 Hz +10 dB 80 Hz +8.0 dB 10 kHz +4.5 dB
Single-to-Noise Ratio:	100 dB (IHF A)
Muting	-55 dB

CD PLAYER

Signal Readout System:	Optical non-contact
Reading Rotation:	About 500 - 200 r.p.m. (constant linear velocity)
Linear Velocity:	1.2 - 1.4 m / s
Error Correction System:	Cross Interleave Reed Solomon code
D / A Converter:	1 bit
Digital Filter:	352.8 kHz 8 times over sampling
Number of Channels:	2 (stereo)
Frequency Response:	5 Hz - 20 kHz

TUNER

Tuning range	FM: 87.9 to 107.9 MHz (200 kHz steps) (U.S. & Canadian models) 87.5 to 108.00 MHz (50 kHz steps) (Other area models)	AM: 530 to 1710 kHz (10 kHz steps) (U.S. & Canadian models) 522 to 1611 kHz (9 kHz steps) (Other area models)
Usable sensitivity	FM: Mono 11.2 dBf, 1.0 μ V (75 ohms IHF) 0.9 μ V (75 ohms DIN) Stereo 17.2 dBf, 2.0 μ V (75 ohms IHF) 23.0 μ V (75 ohms DIN)	AM: 30 μ V
50 dB Quieting sensitivity	FM: Mono 17.2 dBf, 2.0 μ V (75 ohms) Stereo 37.2 dBf, 20.0 μ V (75 ohms)	
Capture ratio	FM: 2.0 dB	
Image rejection ratio	FM: 40 dB (U.S. & Canadian models) 85 dB (Other area models)	AM: 40 dB
IF rejection ratio	FM: 90 dB	AM: 40 dB
Signal to noise ratio	FM: Mono 73 dB, IHF Stereo 67 dB, IHF	AM: 40 dB
Selectivity	FM: 50 dB DIN (\pm 300 kHz at 40 kHz Devi.)	
AM Suppression Ratio:	50 dB	
Harmonic distortion	FM: Mono 0.2% Stereo 0.3%	AM: 0.7 %
Frequency response	FM: 30 to 15,000 Hz (\pm 1.5 dB)	
Stereo separation	FM: 35 dB at 1,000 Hz 25 dB at 100 to 10,000 Hz	
Stereo threshold	FM: 17.2 dBf, 2.0 μ V (75 ohms)	

GENERAL

Power Supply:	AC 120 V, 60 Hz (U.S. & Canadian models) (Some Asian models) AC 230 V, 50 Hz (European models) AC 220-230 V, 50/60 Hz (Other area models)
Power Consumption:	60 W (U.S. & Canadian models) (Some Asian models) 55 W (Other area models)
Dimensions:	205 W x 103 H x 362 D mm (8-1/6" x 4-1/16" x 14-1/4")
Weight:	4.0 kg (8.8 lbs)

Specifications and features are subject to change without notice.
Power supply and voltage vary depending on the area in which the unit is purchased.

CAUTION ON REPLACEMENT OF OPTICAL PICKUP

The laser diode in the optical pickup block is so sensitive to static electricity, surge current and etc., that the components are liable to be broken down or its reliability remarkably deteriorated.

During repair, carefully take the following precautions.
(The following precautions are included in the service parts.)

PRECAUTIONS

- | | |
|---|---|
| <p>1. Ground for the work-desk.
Place a conductive sheet such as a sheet of copper (with impedance lower than 10Mohm) on the work-desk and place the set on the conductive sheet so that the chassis can be grounded.</p> <p>2. Grounding for the test equipments and tools.
Test equipments and toolings should be grounded in order that their ground level is the same the ground of the power source.</p> | <p>3. Grounding for the human body.
Be sure to put on a wrist-strap for grounding whose other end is grounded.
Be particularly careful when the workers wear synthetic fiber clothes, or air is dry.</p> <p>4. Select a soldering iron that permits no leakage and have the tip of the iron well-grounded.</p> <p>5. Do not check the laser diode terminals with the probe of a circuit tester or oscilloscope.</p> |
|---|---|

PROTECTION OF EYES FROM LASER BEAM DURING SERVICING

This set employs a laser. Therefore, be sure to follow carefully the instructions below when servicing.

WARNING!!

**SERVICE WARNING : DO NOT APPROACH THE LASER EXIT WITH THE EYE TOO CLOSELY.
IN CASE IT IS NECESSARY TO CONFIRM LASER BEAM EMISSION, BE SURE TO OBSERVE FROM A DISTANCE OF MORE THAN 30cm FROM THE SURFACE OF THE OBJECTIVE LENS ON THE OPTICAL PICK-UP BLOCK.**

Laser Diode Properties

Material: GaAs/GaALAs

Wavelength: 780nm

Laser output: max. 0.5mW*

Emission Duration: continuous

*This output is the value measured at a distance about 1.8mm from the objective lens surface on the Optical Pick-up Block.

LASER WARNING LABEL

The label shown below are affixed.

1. Warning label



1. Class 1 label





LUOKAN 1
LASERLAITE
KLASS 1
LASER APPARAT

SERVICE PROCEDURE

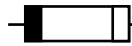
1. Replacing the fuses

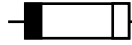
 This symbol located near the fuse indicates that the fuse used is show operating type, For continued protection against fire hazard, replace with same type fuse , For fuse rating, refer to the marking adjust to the symbol.

 Ce symbole indique que le fusible utilise est e lent. Pour une protection permanente, n'utiliser que des fusibles de meme type. Ce demier est indique la qu le present symbol est apposse.

REF.NO.	PART NO.	DESCRIPTION
F901	252157 	1.25A-UL/T-237, Fuse <D, DT>
	252083 	0.4A-SE-EAW, FUSE <P,GR, GT>

NOTE : <D, DT> : 120 V model only
<P,GR, GT> : 230 V model only

2. To initialize the unit

1. Press and the hold down the MEMORY button , then press the After "all lighting " is displayed
2. Press the standby/on button.
After " CLEAR " is displayed, the preset memory and each mode stored in the memory, are initialized and will return to the factory settings.

3. Safety-check out

(Only U.S.A. model)

After correcting the original service problem perform the follwing safety check before releasing the set to the customer
Connect the insulating-resistance tester between the plug of power supply cord and terminal GND on the back panel.

Specifications: More than 10Mohm at 500V

4. Memory Preservation

This unit does not require memory preservation batteries. A built-in memory power back-up system preserves the contents of the memory during power failures and even when the unit is un-plugged. The unit must be plugged in order to charge the back-up system.

The memory preservation period after the unit has been unplugged varies depending on climate and placement of the unit. On the average, memory contents are protected over a period of a few weeks after the last time the unit has been unplugged. This pe-riod is shorter when the unit is exposed to a highly humid cli-mate.

5. Changing the AM band step

With the exception of the worldwide models, a tuning step selector switch is not provided. When you change the band step, change the parts as shown below.

	To 10kHz	To 9kHz
R705	3.3k	10k
R706	5.6k	open

5. Removement of tray

- 1.Remove the top cover
- 2.Turn the locked screw to the clockwise to release the lock of gear.
(Refer to fig-1)

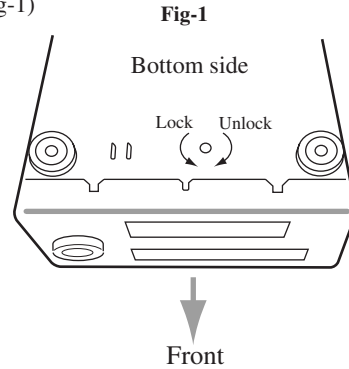

- 3.Pull out the tray.
- 4.Remove the stopper. (Refer to fig-2)

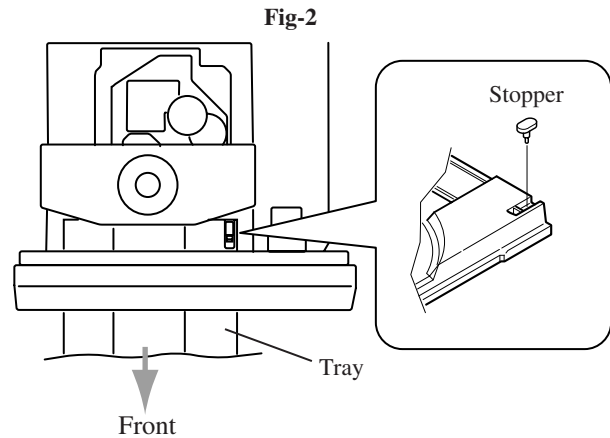

- 5.Press teh tray stopper to the arrow mark direction and remove the tray ass'y. (Refer to fig-3)

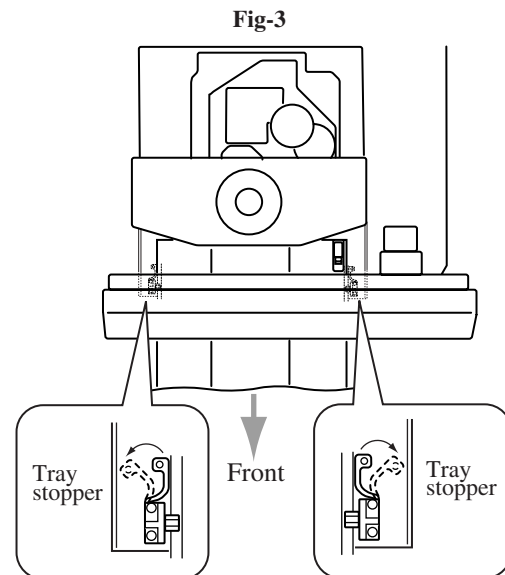

MICROPROCESSOR TERMINAL DESCRIPTION (Q701 : MPD78042GF-3B9)

NO.	Function	I/O	Description	NO.	Function	I/O	Description
1	4G	O		41	POWER AMP	O	Output pin for power supply control of power amplifier
2	5G	O		42	RDS DATA	I	Data input pin from RDS decoder IC.
3	6G	O		43	RDSSIG	I	Signal input pin from RDS decoder IC.
4	7G	O	Grid output pins. (4G~10G)	44	SCOR	I	Sub code frame detection input pin from signal processing IC(CXD2589Q).
5	8G	O		45	RDSSCK	I	Clock input pin from RDS decoder IC.
6	9G	O		46	SYSIN	I	System code input pin.
7	10G	O		47	REMIN	I	Signal input pin for remote controller.
8	VDD	I	Power supply pin.	48	IC	I	Internal connection pin. Not used.
9	CDCLK	O	Command output pin to transfer the clock signal to signal processing IC(CXD2589Q).	49	SYSOUT	O	System code output pin.
10	XLT	O	Command output pin to transfer the latch signal to signal processing IC(CXD2589Q).	50	TUMUT	O	Muting control signal output pin for tuner section.
11	CDDATA	O	Command output pin to transfer the data signal to signal processing IC(CXD2589Q).	51	ANGMUT	O	Muting control signal output pin for amplifier section.
12	SENS20	I	Sense signal input pin from servo IC(CXA1992)	52	VDD	I	Power supply pin.
13	DSPMUT	O	Digital mute output pin to signal processing IC(CXD2589Q).	53	POWERCD	O	Output pin for power supply control of CD section.
14	SQCK	O	Subcode reading clock output pin to signal processing IC(CXD2589Q).	54	LED1	O	Acoustic presence indicator (red) control output pin.
15	SENS	I	Sense signal input pin from signal processing IC(CXD2589Q).	55	XRST	O	Reset signal output pin of signal processing IC and servo IC.
16	SQSO	I	Subcode data input pin from signal processing IC(CXD2589Q).	56	CDAUTOADJ	I	Set pin of self adjustment ON/OFF of CD
17	RESET	I	System reset input pin.	57	OPEN	O	CD tray open control output pin.
18	STEREO	I	FM stereo broadcast detection input pin.	58	CLOSE	O	CD tray close control output pin.
19	SD	I	Broadcast detection input pin.	59	LED2	O	Acoustic presence indicator (green) control output pin.
20	AVSS	I	Ground pin for A/D converter.	60	P1		
21	VOLDOWN	O	Volume control output pin.	61	P2		
22	VOLUP	O	Volume control output pin.	62	P3		
23		-	Not used.	63	P4		
24	AREA	I	Initialization input pin for destination switch.	64	P5		
25	IN/OUT	I	Input pin for CD tray open/close detection switches.	65	P6		
26	SIGNAL	I	Signal level input pin for automatic memory.	66	P7		
27	K1	I	Operation key connection pin.	67	P8		
28	KO	I	Operation key connection pin.	68	P9		
29	AVDD	I	Power supply pin for A/D converter.	69	P10		
30	AVREF	I	Reference voltage input pin for A/D converter.	70	P11		
31	POFF	I	Power failure input pin.	71	VLOAD		Power supply pin for FL tube.
32	XT2	O	Sub clock connection pin. Not used.	72	P12		
33	VSS	I	Ground pin.	73	P13		
34	X1	I	Master clock connection pin.	74	P14		
35	X2	I	Master clock connection pin.	75	P15		
36	RCLK	O	Serial clock output pin to PLL and function switch ICs (TC9273, TC9162).	76	P16		
37	RDATA	O	Serial data output pin to PLL and function switch ICs (TC9273, TC9162).	77	P17		
38	FREQCAL	O	Frequency output terminal for clock adjustment	78	1G		
39	FCE	O	Serial latch output pin to function switch ICs (TC9273, TC9162).	79	2G		
40	PLLCE	O	Serial latch output pin to PLL IC.	80	3G		

IC BLOCK DIAGRAM AND DESCRIPTIONS

Q101:CXA1992BR (RF Signal Processing Servo Amplifier)

Block Diagram

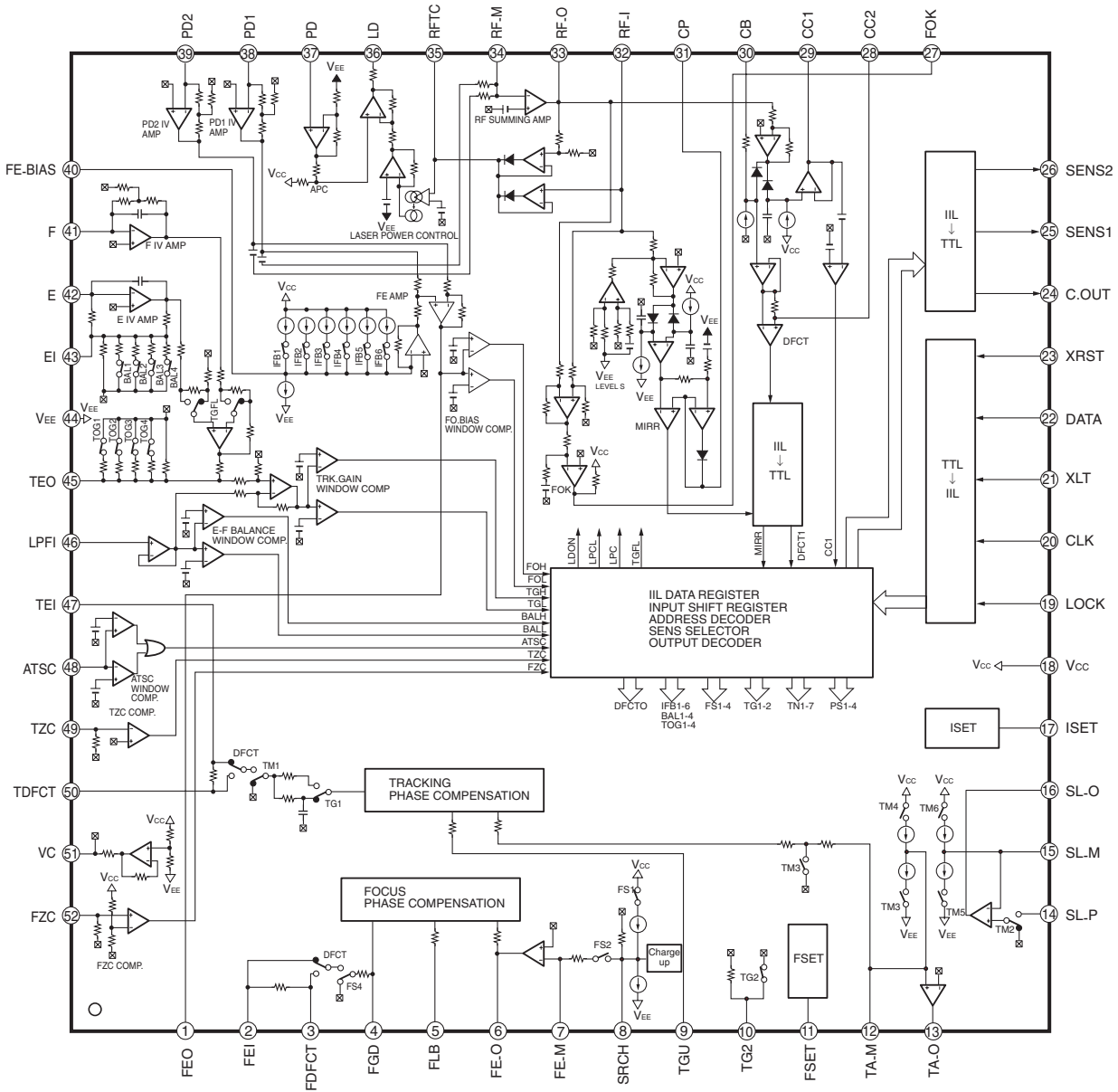

Terminal description

Pin No.	Symbol	I/O	Description	Pin No.	Symbol	I/O	Description
1	FEO	O	Focus error amplifier output. Connected internally to the window comparator input for bias adjustment.	26	SENS2	O	Outputs DFCT2, MIRR, BALL, TGL, FOL, and others according to the command from the CPU.
2	FEI	I	Focus error input.	27	FOK	O	Focus OK comparator output.
3	FDFACT	I	Capacitor connection pin for defect time constant.	28	CC2	I	Input for the defect bottom hold output with capacitance coupled.
4	FGD	I	Ground this pin through a capacitor for cutting the focus servo high-frequency gain.	29	CC1	O	Defect bottom hold output. Connected internally to the interruption comparator input.
5	FLB	I	External time constant setting pin for boosting the focus servo low-frequency.	30	CB	I	Connection pin for defect bottom hold capacitor.
6	FE_O	O	Focus drive output.	31	CP	I	Connection pin for MIRR hold capacitor. MIRR comparator non-inverted input.
7	FE_M	I	Focus amplifier inverted input.	32	RF_I	I	Input for the RF summing amplifier output with capacitance coupled.
8	SRCH	I	External time constant setting pin for generating focus search waveform.	33	RF_O	O	RF summing amplifier output. Eyepattern check point.
9	TGU	I	External time constant setting pin for switching tracking high-frequency gain.	34	RF_M	I	RF summing amplifier inverted input. The RF amplifier gain is determined by the resistance connected between this pin and RFO pin.
10	TG2	I	External time constant setting pin for switching tracking high-frequency gain.	35	RFTC	I	External time constant setting pin during RF level control.
11	FSET	I	Peak frequency setting pin for focus and tracking phase compensation amplifier.	36	LD	O	APC amplifier output.
12	TA_M	I	Tracking amplifier inverted input.	37	PD	I	APC amplifier input.
13	TA_O	O	Tracking drive output.	38	PD1	I	RF I-V amplifier inverted input. Connect these pins to the photo diode A + C and B + D pins.
14	SL_P	I	Sled amplifier non-inverted input.	39	PD2	I	
15	SL_M	I	Sled amplifier inverted input.	40	FE_BIAS	I	Bias adjustment of focus error amplifier. Leave this pin open for automatic adjustment.
16	SL_O	O	Sled drive output.	41	F	I	F I-V and E I-V amplifier inverted input.
17	ISET	I	Connect an external capacitance to set the current which determines the Focus search, Track jump, and Sled kick heights.	42	E	I	Connect these pins to photo diodes F and E.
18	VCC	I	Positive power supply.	43	EI	—	I-V amplifier E gain adjustment. (When not using automatic balance adjustment)
19	LOCK	I	The sled overrun prevention circuit operates when this pin is Low. (no pull-up resistance)	44	VEE	—	Negative power supply.
20	CLK	I	Serial data transfer clock input from CPU. (no pull-up resistance)	45	TEO	O	Tracking error amplifier output. E-F signal is output.
21	XLT	I	Latch input from CPU. (no pull-up resistance)	46	LPFI	I	Comparator input for balance adjustment. (Input from TEO through LPF)
22	DATA	I	Serial data input from CPU. (no pull-up resistance)	47	TEI	I	Tracking error input.
23	XRST	I	Reset input; resets at Low. (no pull-up resistance)	48	ATSC	I	Window comparator input for ATSC detection.
24	C. OUT	O	Track number count signal output.	49	TZC	I	Tracking zero-cross comparator input.
25	SENS1	O	Outputs FZC, DFCT1, TZC, BALH, TGH, FOH, ATSC, and others according to the command from CPU.	50	TDFCT	I	Capacitor connection pin for defect time constant.
				51	VC	O	(VCC + VEE)/2 direct voltage output.
				52	FZC	I	Focus zero-cross comparator input.

Q301:CXD2589Q (CD Digital Signal Processor)

Bloch Diagram

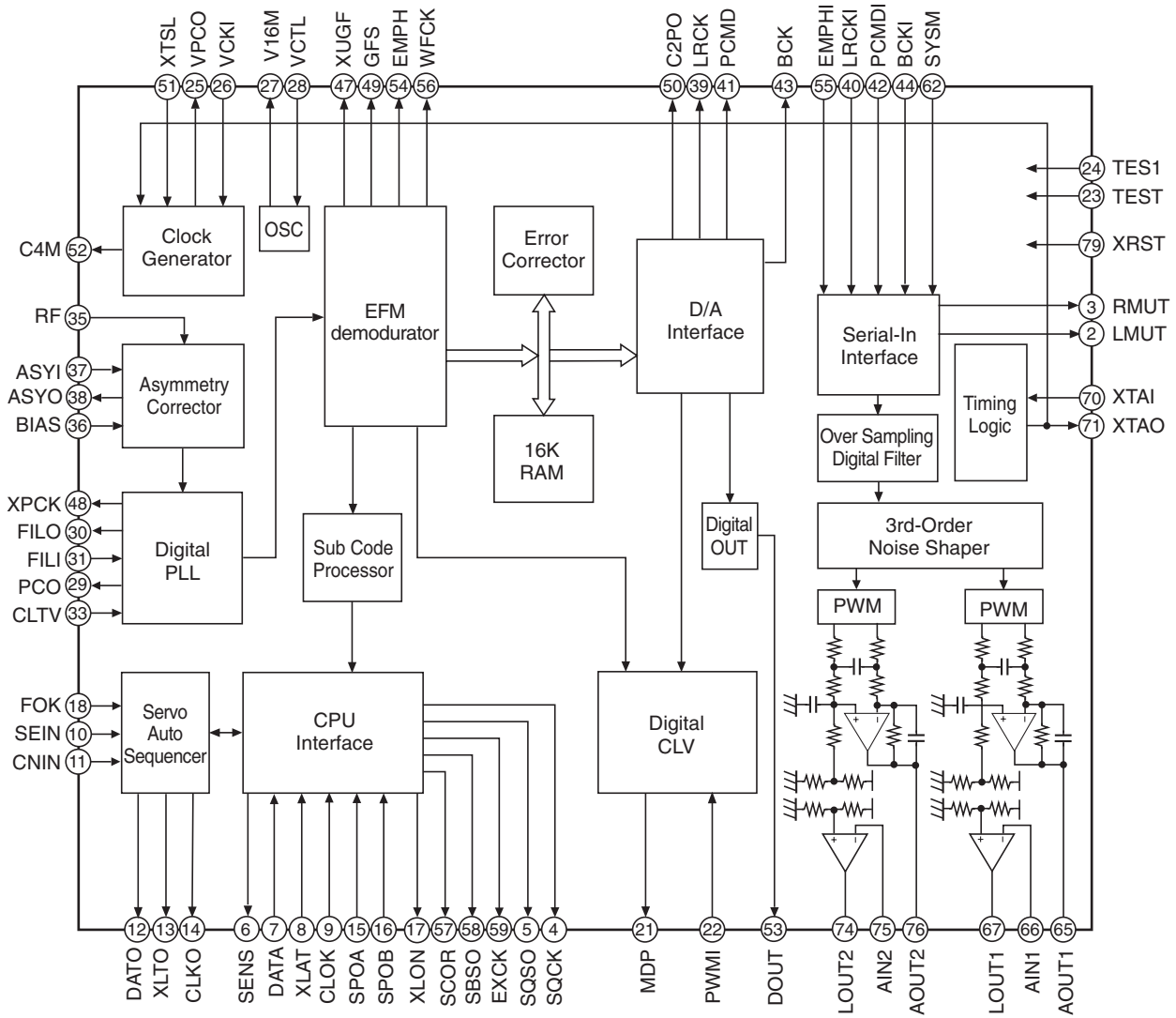

Terminal description

Pin No.	Symbol	I/O	Description	Pin No.	Symbol	I/O	Description
1	VSS	—	GND	43	BCK	O	D/A interface. Bit clock output.
2	LMUT	O	Left-channel zero detection flag.	44	BCKI	I	D/A interface. Bit clock input.
3	RMUT	O	Right-channel zero detection flag.	45	VSS	—	GND
4	SQCK	I	SQSO readout clock input.	46	VDD	—	Power supply (+5V).
5	SQSO	O	Sub Q 80-bit serial output.	47	XUGF	O	XUGF output. Switched to MNT1 or RFCK output by a command.
6	SENS	O	SENS output to CPU.	48	XPCK	O	XPLCK output. Switched to MNT0 output by a command.
7	DATA	I	Serial data input from CPU.	49	GFS	O	GFS output. Switched to MNT3 or XRAOF output by a command.
8	XLAT	I	Latch input from CPU. Serial data is latched at the falling edge.	50	C2PO	O	C2PO output. Switched to GTOP output by a command.
9	CLOK	I	Serial data transfer clock input from CPU.	51	XTSL	I	Crystal selector input. Low: 16.9344MHz; high: 33.8688MHz.
10	SEIN	I	SENS input from SSP.	52	C4M	O	4.2336MHz output. 1/4 frequency-divided VCKI output in CAV-W mode.
11	CNIN	I	Track jump count signal input.	53	DOU	O	Digital Out output.
12	DATO	O	Serial data output to SSP.	54	EMPH	O	Outputs a high signal when the playback disc has emphasis, and a low signal when there is no emphasis.
13	XLTO	O	Serial data latch output to SSP. Latched at the falling edge.	55	EMPHI	I	Inputs a high signal when de-emphasis is on, and a low signal when de-emphasis is off.
14	CLKO	O	Serial data transfer clock output to SSP.	56	WFCK	O	WFCK output.
15	SPOA	I	Microcomputer extended interface (input A).	57	SCOR	O	Outputs a high signal when either subcode sync S0 or S1 is detected.
16	SPOB	I	Microcomputer extended interface (input B).	58	SBSO	O	Sub P to W serial output.
17	XLON	O	Microcomputer extended interface (output).	59	EXCK	I	SBSO readout clock input.
18	FOK	I	Focus OK input. Used for SENS output and the servo auto sequencer.	60	VSS	—	GND
19	VDD	—	Power supply (+5V).	61	VDD	—	Power supply (+5V).
20	VSS	—	GND	62	SYSM	I	Mute input. Active when high.
21	MDP	O	Spindle motor servo control.	63	AVSS	—	Analog GND.
22	PWMI	I	Spindle motor external control input.	64	AVDD	—	Analog power supply (+5V).
23	TEST	I	TEST pin; normally GND.	65	AOUT1	O	Left-channel analog output.
24	TES1	I	TEST pin; normally GND.	66	AIN1	I	Left-channel operational amplifier input.
25	VPCO	O	Charge pump output for the wide-band EFM PLL.	67	LOUT1	O	Left-channel LINE output.
26	VCKI	I	VCO2 oscillation input for the wide-band EFM PLL.	68	AVSS	—	Analog GND.
27	V16M	O	VCO2 oscillation output for the wide-band EFM PLL.	69	XVDD	—	Power supply for master clock.
28	VCTL	I	VCO2 control voltage input for the wide-band EFM PLL.	70	XTAI	I	Crystal oscillation circuit input. Input the external master clock via this pin.
29	PCO	O	Master PLL charge pump output.	71	XTAO	O	Crystal oscillation circuit output.
30	FIL0	O	Master PLL (slave = digital PLL) filter output.	72	XVSS	—	GND for master clock.
31	FILI	I	Master PLL filter input.	73	AVSS	—	Analog GND.
32	AVSS	—	Analog GND.	74	LOUT2	O	Right-channel LINE output.
33	CLTV	I	Master VCO control voltage input.	75	AIN2	I	Right-channel operational amplifier input.
34	AVDD	—	Analog power supply (+5V).	76	AOUT2	O	Right-channel analog output.
35	RF	I	EFM signal input.	77	AVDD	—	Analog power supply (+5V).
36	BIAS	I	Constant current input of the asymmetry circuit.	78	AVSS	—	Analog GND.
37	ASYI	I	Asymmetry comparator voltage input.	79	XRST	I	System reset. Reset when low.
38	ASYO	O	EFM full-swing output (low = VSS, high = VDD).	80	VDD	—	Power supply (+5V).
39	LRCK	O	D/A interface. LR clock output $f = F_s$.				
40	LRCKI	I	LR clock input.				
41	PCMD	O	D/A interface. Serial data output (two's complement, MSB first).				
42	PCMDI	I	D/A interface. Serial data input (two's complement, MSB first).				

Notes) • PCMD is an MSB first, two's complement output.

- GTOP is used to monitor the frame sync protection status. (High: sync protection window open.)
- XUGF is the frame sync obtained from the EFM signal, and a negative pulse. It is the signal before sync protection.
- XPLCK is the inverse of the EFM PLL clock. The PLL is designed so that the falling edge of XPLCK and the EFM signal transition point coincide.
- GFS goes high when the frame sync and the insertion protection timing match.
- RFCK is derived with the crystal accuracy. This signal has a cycle of 136 μ s (during normal speed).
- C2PO represents the data error status.
- XRAOF is generated when the 16K RAM exceeds the $\pm 4F$ jitter margin.

Q401:TC9273N-007 (Analog function switch)

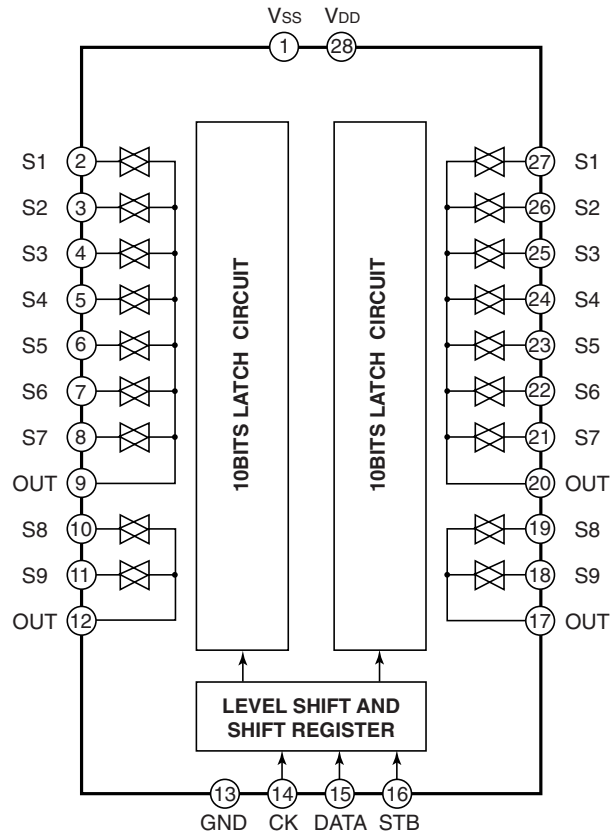

Q402:TC9162AF Analog function switch

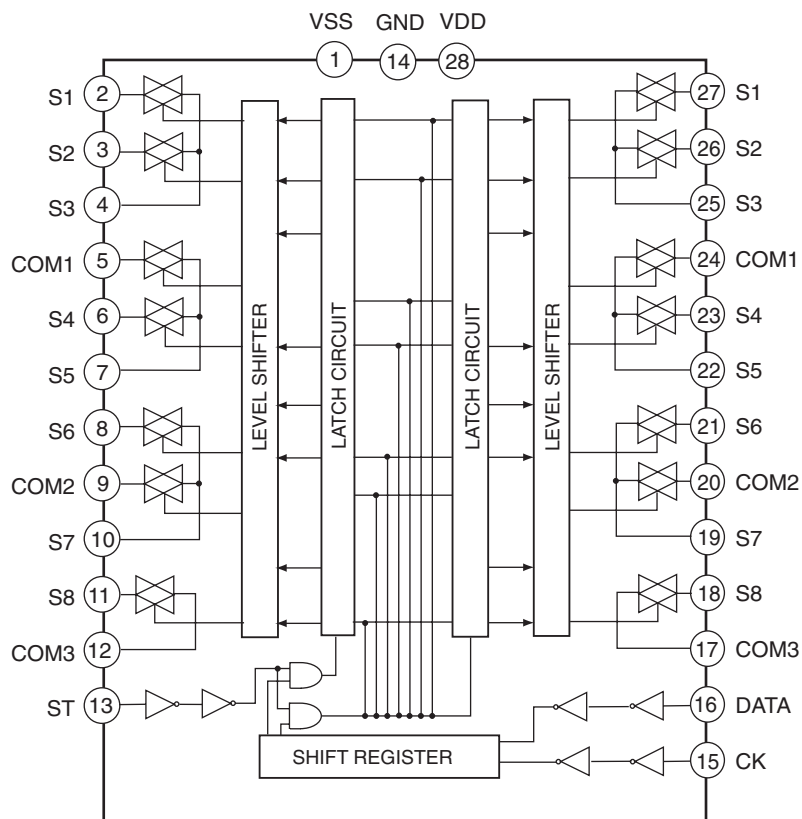

Q102:LA6541D (4-channel ridge driver for Compact Discs)

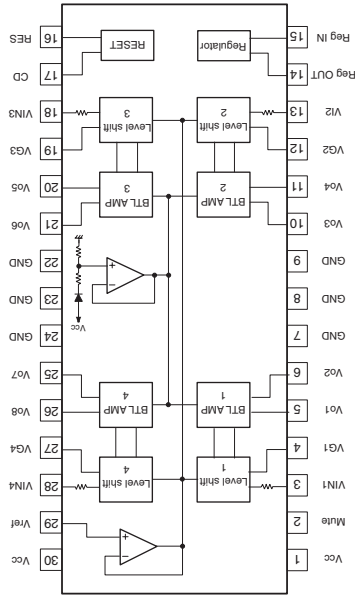

Pin No.	Pin Name	Description (Function)
1	VCC	Power supply (shorted with pin 30)
2	Mute	ON/OFF control for all BTL AMP outputs
3	V _{IN1}	BTL AMP 1 input
4	V _{G1}	BTL AMP 1 input (for gain control)
5	V _{O1}	BTL AMP 1 output (non-inverting side)
6	V _{O2}	BTL AMP 1 output (inverting side)
7	GND	GND (minimum electric potential)
8	GND	GND (minimum electric potential)
9	GND	GND (minimum electric potential)
10	V _{O3}	BTL AMP 2 output (inverting side)
11	V _{O4}	BTL AMP 2 output (non-inverting side)
12	V _{G2}	BTL AMP 2 input (for gain control)
13	V _{IN2}	BTL AMP 2 input
14	REG OUT	Connection for collector of external transistor (PNP); 5 V supply output
15	REG IN	Connection for base of external transistor (PNP)
16	RES	Reset output
17	C _D	Reset output delay time setting (with capacitor)
18	V _{IN3}	BTL AMP 3 input
19	V _{G3}	BTL AMP 3 input (for gain control)
20	V _{O5}	BTL AMP 3 output (non-inverting side)
21	V _{O6}	BTL AMP 3 output (inverting side)
22	GND	GND (minimum electric potential)
23	GND	GND (minimum electric potential)
24	GND	GND (minimum electric potential)
25	V _{O7}	BTL AMP 4 output (inverting side)
26	V _{O8}	BTL AMP 4 output (non-inverting side)
27	V _{G4}	BTL AMP 4 input (for gain control)
28	V _{IN4}	BTL AMP 4 input
29	V _{REF}	Reference voltage input for level shift circuit
30	VCC	Power supply (shorted with pin 1)

Q180:BU1923 (RDS Decoder)

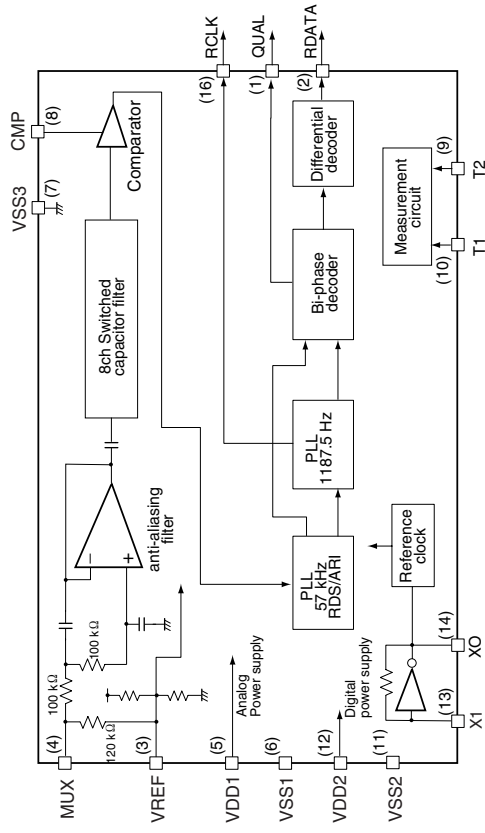

Pin No.	Symbol	Pin name	Function
1	QUAL	Demodulator quality	Good data : High , bad data : Low
2	RDATA	Demodulator data	Refer to output data trimming
3	Vref	Reference voltage	1/2 VDD1
4	MUX	Input	Composite signal input
5	VDD1	Analog power supply	4.5 V to 5.5 V
6	Vss1	GND	-
7	Vss3	GND	-
8	CMP	Comparator input	C-junction
9	T2	Test input	Open or connected to ground
10	T1	Test input	Open or connected to ground
11	VDD2	Digital power supply	4.5 V to 5.5 V
12	Vss2	GND	-
13	X1	Crystal oscillator	Connects to 4.332 MHz oscillator
14	XO	Reference clock	-
15	(NC)	-	-
16	RCLK	Demodulator clock	1187.5 Hz clock

Q103:TA7291S (motor driver)

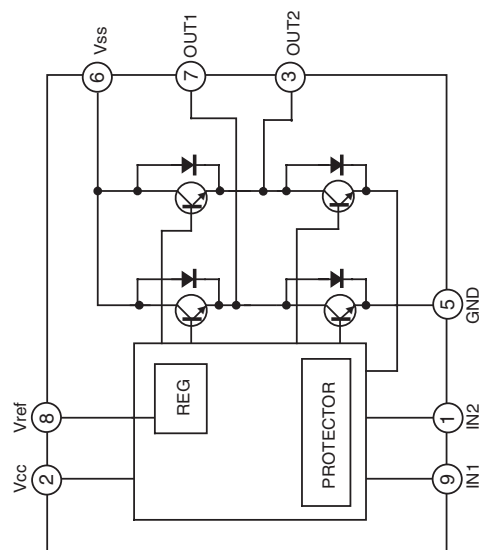

INPUT		OUTPUT		MODE
IN1	IN2	OUT1	OUT2	
0	0	∞	∞	STOP
1	0	H	L	CW/CCW
0	1	L	H	CCW/SW
1	1	L	L	BRAKE

CCW : Counter clockwise direction
 CW : Clockwise direction

Q691:TC7WU04FU (triple inverters)

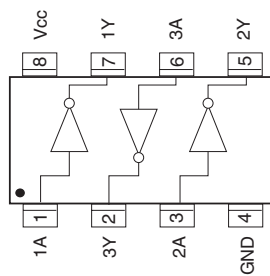

Truth table

A	Y
L	H
H	L

Q751 : 10BT-167GK (FL TUBE)

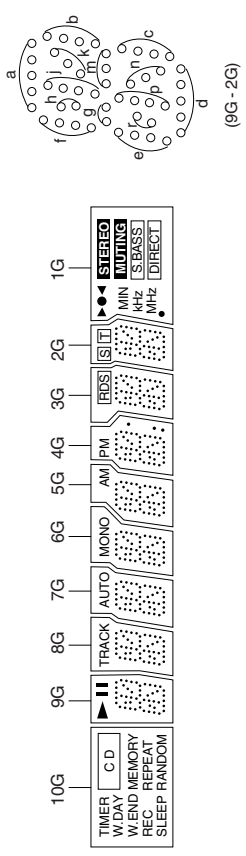

	10G	9G	8G	7G	6G	5G	4G	3G	2G	1G
P1	-	a	a	a	a	a	a	a	a	-
P2	W.DAY	i	i	i	i	i	i	i	i	MUTING
P3	W.END	h	h	h	h	h	h	h	h	MIN
P4	MEMORY	k	k	k	k	k	k	k	k	S.BASS
P5	-	b	b	b	b	b	b	b	b	-
P6	-	f	f	f	f	f	f	f	f	-
P7	-	g	g	g	g	g	g	g	g	-
P8	REC	m	m	m	m	m	m	m	m	MHz
P9	-	c	c	c	c	c	c	c	c	-
P10	-	e	e	e	e	e	e	e	e	-
P11	REPEAT	n	n	n	n	n	n	n	n	MHz
P12	RANDOM	r	r	r	r	r	r	r	r	DIRECT
P13	-	p	p	p	p	p	p	p	p	-
P14	-	d	d	d	d	d	d	d	d	-
P15	TIMER	Δ	TRACK	AUTO	MONO	AM	PM	RDS	S	▷◁
P16	CD	□	-	-	-	-	Col	-	T	STEREO
P17	SLEEP	-	-	-	-	-	Dp	-	-	○

CD MECHANISM EXPLODEE VIEW(1)

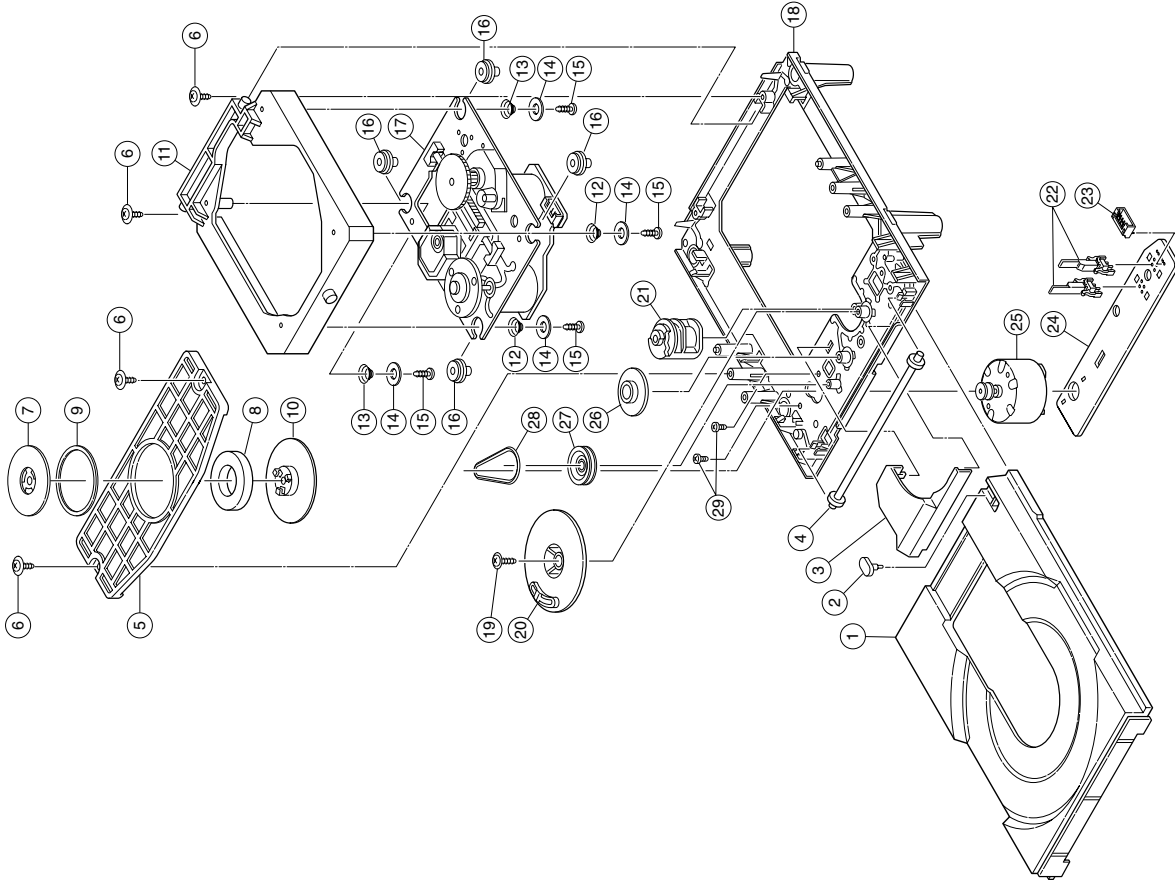

CD MECHANISM EXPLODEE VIEW(2)

pickup drive unit

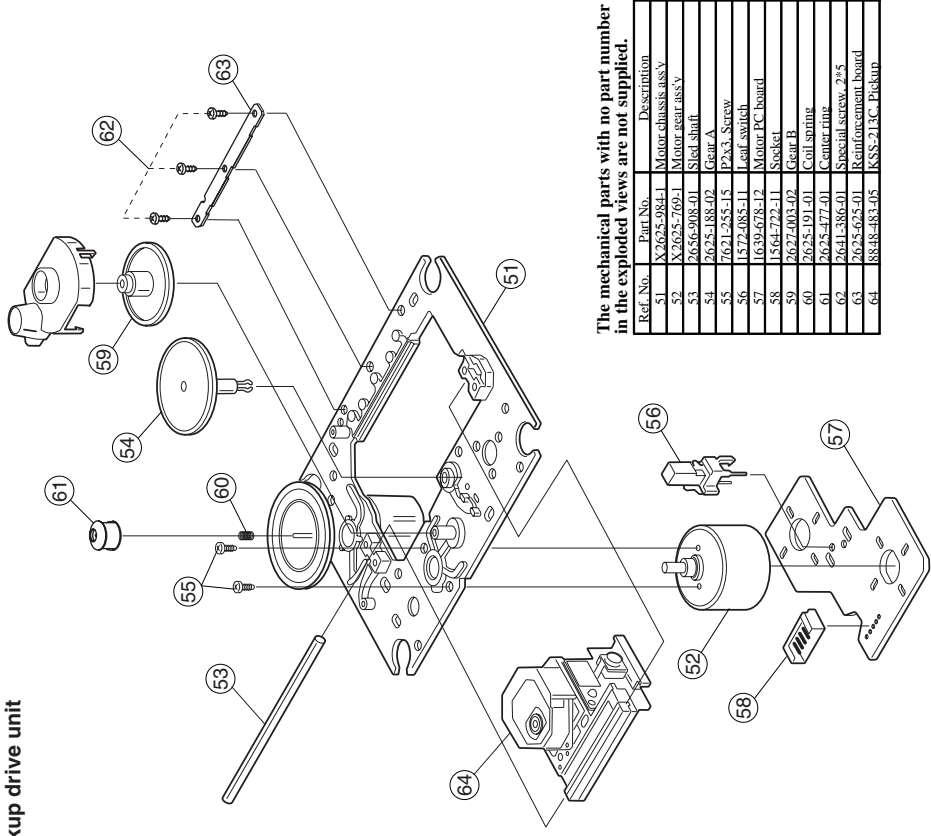

The mechanical parts with no part number in the exploded views are not supplied.

Ref. No.	Part No.	Description
51	X2625-284-1	Motor chassis assy
52	X2625-709-1	Motor gear assy
53	2625-308-01	Steel Shaft
54	2625-188-02	Gear A
55	2625-188-02	PA3.1 Screw
56	1872485-15	Leaf switch
57	1639478-12	Motor PC board
58	1564722-11	Socket
59	2625-403-02	Gear B
60	2625-191-01	Coil spring
61	2625-477-01	Center pin
62	2641-386-01	Special screw 2*5
63	2625-695-01	Reinforcement board
64	18848-483-05	KSS-23C Pickup

Ref. No.	Part No.	Description
1	2646-290-01	Tray
2	2625-544-01	Stomper
3	2625-544-01	Gear cover
4	2625-535-01	Tray Gear
5	2625-546-01	Chuckline plate
6	PTPW H2.6*7.7 Screw	
7	2625-537-01	Chuckline vokes
8	1452-493-21	Magnet
9	2625-544-02	Damper
10	2646-291-01	Chuckline pulley
11	2646-288-01	Sub chassis
12	2627-236-01	Coil spring (front)
13	2627-235-01	Coil spring (back)
14	2646-289-01	Motor chassis
15	PT2.0*10 Screw	

Ref. No.	Part No.	Description
16	2627-234-01	Insulator
17	KSM-21.3CCM	
18	2625-552-06	Main chassis
19	3319-501-51	PTPW H2.6*16. Screw
20	2625-547-01	Drive Gear
21	2625-545-04	Control cam
22	1692-667-11	Leaf switch
23	1564-721-11	Socket
24	1640-523-11	Loading motor assy
25	X2625-17-1	Loading motor
26	2625-574-02	Middle gear
27	2625-536-02	Loading pulley
28	3653-387-00	M bed
29	PT2.0*2.5. Screw	

REPLACEMENT OF OPTICAL PICKUP

The laser diode in the optical pickup block is so sensitive to static electricity, surge current and etc. That the components are liable to be broken down or its reliability remarkably deteriorated. During repair, carefully take the following precautions.

Do not touch the optical pickup object lens with the hands.

- (1) The machine screw of four points which is the fixation of mechanism is removed, mechanism is upset, and PC which is about the bottom of mechanism is seen. (Fig-1, Fig-2)

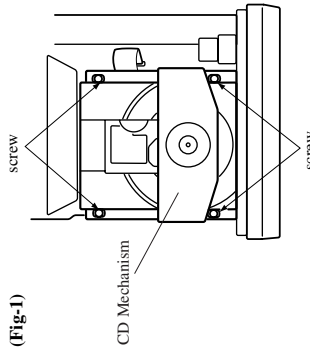

(Fig-1)

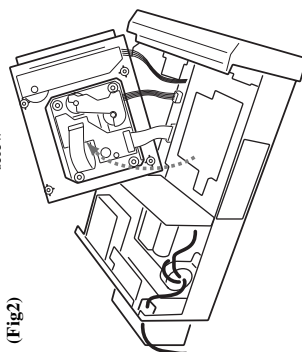

- (2) The machine screw is removed and CD connector PC board (NAETC-6883) is removed from the main body of CD mechanism. (Fig-3)

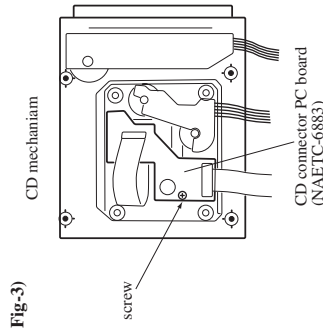

(Fig-3)

- (3) Connect J293 (or LD short terminal 2) on CD Connector PC board (NAETC-6883) first when you replace an optical pickup. (Fig-4)

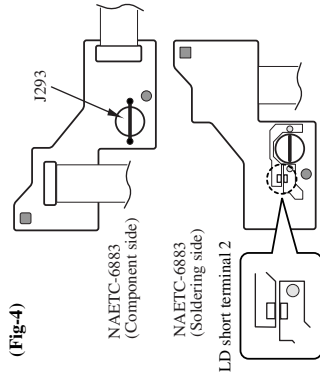

(Fig-4)

- (4) Remove socket P351 between the CD Connector PC board and the Main circuit PC board. (Fig-5)

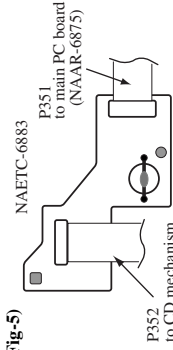

(Fig-5)

- (5) Solder the LD short terminal 1 on mechanism. (Fig-6)
- (6) Disconnect the flexible flat cable P352. (Fig-6)

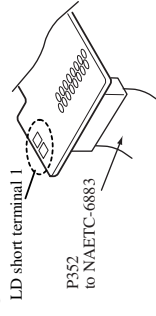

(Fig-6)

- (7) Replace the optical pickup.
- (8) Connect the flexible flat cable P352. (Fig-6)
- (9) Unsolder the LD terminal 1 on mechanism. (Fig-6)
- (10) Connect the socket P351 between CD Connector and Main circuit PC boards (NAAR-6875). (Fig-5)
- (11) Cut J293, (or Unsolder the LD terminal 2) (Fig-4)

CHASSIS EXPLODED VIEW PARTS LIST

REFF. NO.	PART NO.	DESCRIPTION	REFF. NO.	PART NO.	DESCRIPTION
1	27111168	Front bracket	U1	IH445574-1A	NAAF-6874-1A, Selector circuit PC board ass'y <D>
6	838130088	3TTTB+8B, Self tapping screw		IH445574-1B	NAAF-6874-1B, Selector circuit PC board ass'y <P>
7	27100384	Chassis		IH445574-1C	NAAF-6874-1C, Selector circuit PC board ass'y <DT>
8	27190693A	KG15-6RF, Holder	U2	IH445578-1D	NAAF-6878-1D, Power supply PC board ass'y <GR, GT>
9	27191112	KG15-6RF, Holder		IH445578-1B	NAPS-6878-1B, Power supply PC board ass'y <P>
10	27191110	Holder, M		IH445578-1C	NAPS-6878-1C, Power supply PC board ass'y <DT>
12	27175253-1A	Leg	U3	IH445579-1A	NADIS-6879-1A, Display circuit PC board ass'y <D>
14	27300750	Busing, cord		IH445579-1B	NADIS-6879-1B, Display circuit PC board ass'y <DT>
15	830440069	4FTTC-66C(BC), Self tapping screw		IH445579-1D	NADIS-6879-1D, Display circuit PC board ass'y <GR, GT>
16	831430088	3TTTW+8B(BC), Self tapping screw		IH445580-1A	NAAF-6880-1A, Power amplifier PC board ass'y <D>
20	28184781	Cover, HT	U4	IH445580-1B	NAAF-6880-1B, Power amplifier PC board ass'y <P>
22	28184782	Top cover		IH445580-1D	NAAF-6880-1D, Power amplifier PC board ass'y <DT>
23	838930088	Knob, volume		IH445581-1A	NAETC-6881-1A, Speaker terminal PC board ass'y <D>
24	28325775A	Tray panel, CD		IH445581-1B	NAETC-6881-1B, Speaker terminal PC board ass'y <P>
25	28148447	Shield plate	U5	IH445581-1C	NAETC-6881-1C, Speaker terminal PC board ass'y <DT>
26	27150456	Rear panel<D>		IH445581-1D	NAETC-6881-1D, Speaker terminal PC board ass'y <GR, GT>
31	27122738	Rear panel<P, GR, DT, GT>		IH445582-1A	NAETC-6882-1A, Digital output PC board ass'y <D>
33	838430068	3TTTB+6B(BC), Self tapping screw	U6	IH445582-1B	NAETC-6882-1B, Digital output PC board ass'y <DT>
41	27212217	Front panel<D, GR, DT, GT>		IH445582-1C	NAETC-6882-1C, Digital output PC board ass'y <GR, GT>
43	2726027A	Guide, volume	U7	25136900	NCETC-6900, PC board for holder <P, GR, GT>
46	28198909	Flacet		IH445583-1A	NAAR-6875-1A, CD circuit PC board ass'y <D>
47	28191888	Clear plate		IH445583-1B	NAAR-6875-1B, CD circuit PC board ass'y <P>
50	880009	Plastic rivet, NRP-345<P, GR, GT>		IH445583-1C	NAAR-6875-1C, CD circuit PC board ass'y <DT>
52	29362650	Label, Spec. <D>		IH445583-1D	NAAR-6875-1D, CD circuit PC board ass'y <GR, GT>
	29362700	Label, Spec. <GR>	U8	IH445575-1A	NAETC-6883-1A, Connector PC board ass'y <D>
	29362651	Label, Spec. <DT>		IH445575-1B	NAETC-6883-1B, Connector PC board ass'y <DT>
	29362699	Label, Spec. <GT>	U9	IH445575-1C	NAETC-6883-1C, Connector PC board ass'y <GR, GT>
	29362652	Label, Spec. <P>		IH445583-1A	NAETC-6883-1A, Connector PC board ass'y <D>
53	29362572A	Label, Warning <D>		IH445583-1B	NAETC-6883-1B, Connector PC board ass'y <DT>
54	29362571	Label, Warning <P, GR, DT, GT>		IH445583-1C	NAETC-6883-1C, Connector PC board ass'y <GR, GT>
55	29362885	Label	U10	240134	TFCEIU114A, Tuner unit<D>
	252157	1.25A-UL/T-237, Fuse<D, DT>		240135	TFCEIEST12A, Tuner unit<GR, GT, P, DT>
P901	252083	0.4A-SE-EAW, Fuse<GR, GT>			
P302	200990500	NSAS-10P0654, Socket			
P303	20022391210	NSAS-12P0723, Socket			
P351	2047161012	NGFC7-161012, Flexible flat cable			
P352	2042161022	NGFC2-161022, Flexible flat cable			
P701	2047360612	NGFC7-360612, Flexible flat cable			
P778	2047151012	NGFC7-151012, Flexible flat cable			
P901	253294HDK	AS-UC-2#18, Power supply cord<D, DT>			
	253294HIT	AS-C-EE, Power supply cord<GR>			
	253273HIT	AS-C-EE, Power supply cord<P, GT>			
Q557, Q558	2203384	2SC3831-Y or			
Q559, Q560	2203383	2SC3831-O, Transistor			
	2203394	* 2SA1488-Y or			
	2203393	* 2SA1488-O, Transistor			
Q557A	27160468	Heat sink			
Q557B	801433	3SM588, SW+4H(BC), Special screw			
T901	2301452	NPT-139 ID, Power transformer<D, DT>			
	2301453	NPT-139 IG, Power transformer<GR, GT>			
Z1	2480018A	NCD-1708, CD mechanism			
Z2	24840133	Boos, PCB			
Z3	24840135	Boos, PCB			
Z5	838120080	2TTTB+8P, Self tapping screw			
Z6	838426088	2.6TTTB+8B(BC), Self tapping screw			

NOTE: THE COMPONENTS IDENTIFIED BY THE MARK Δ ARE CRITICAL FOR RISK OF FIRE AND ELECTRIC SHOCK. REPLACE ONLY WITH PART NUMBER SPECIFIED.

<D> : USA & Canadian models only
 <DT> : Taiwanese model only
 <P> : European model only
 <GR> : Chinese model only
 <GT> : Asian model only

CAUTION: Replacement of the transistor of mark * if necessary, must be made from the same beta group(HFE) as the original type.

CHASSIS EXPLODED VIEW

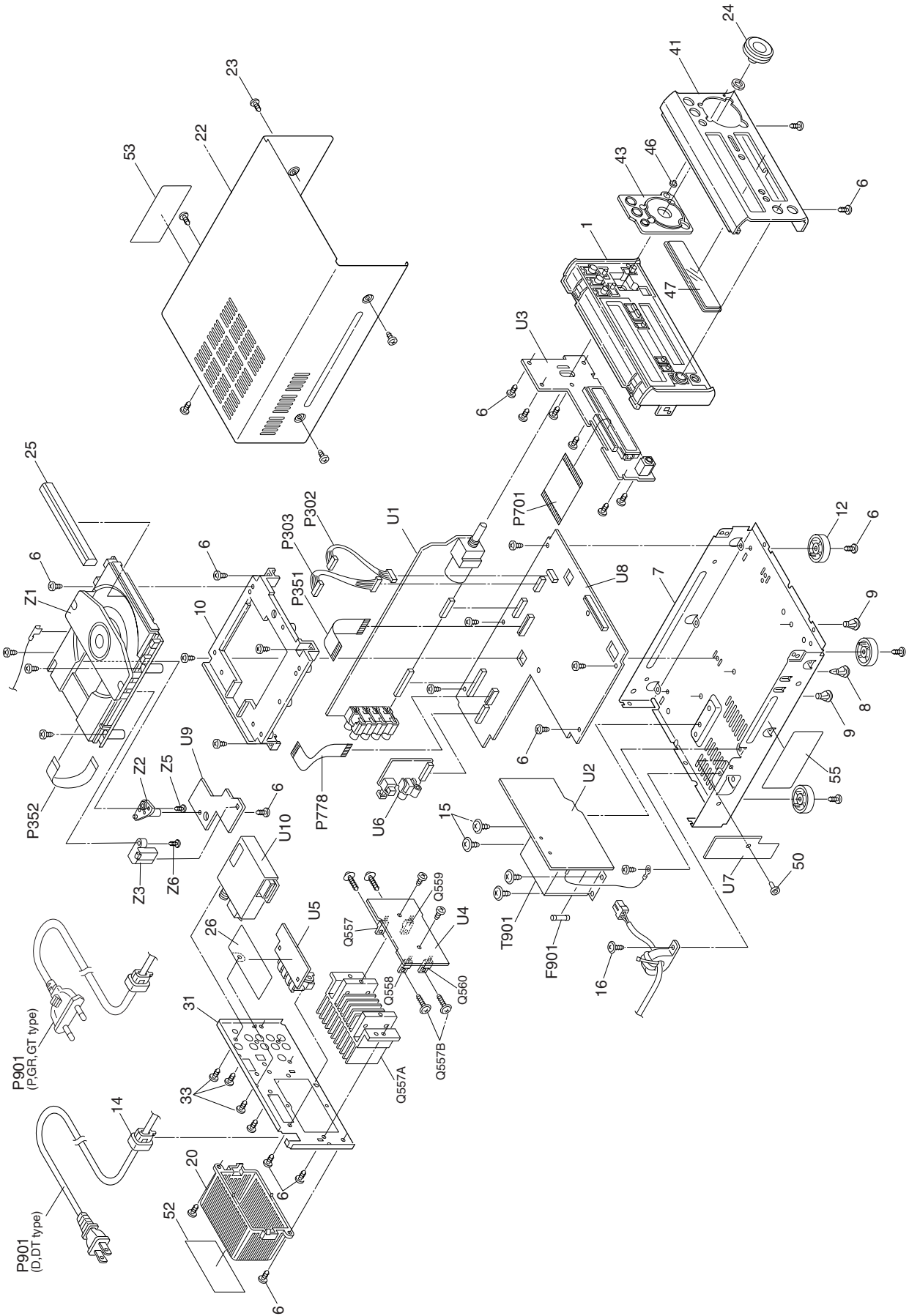

BLOCK DIAGRAM

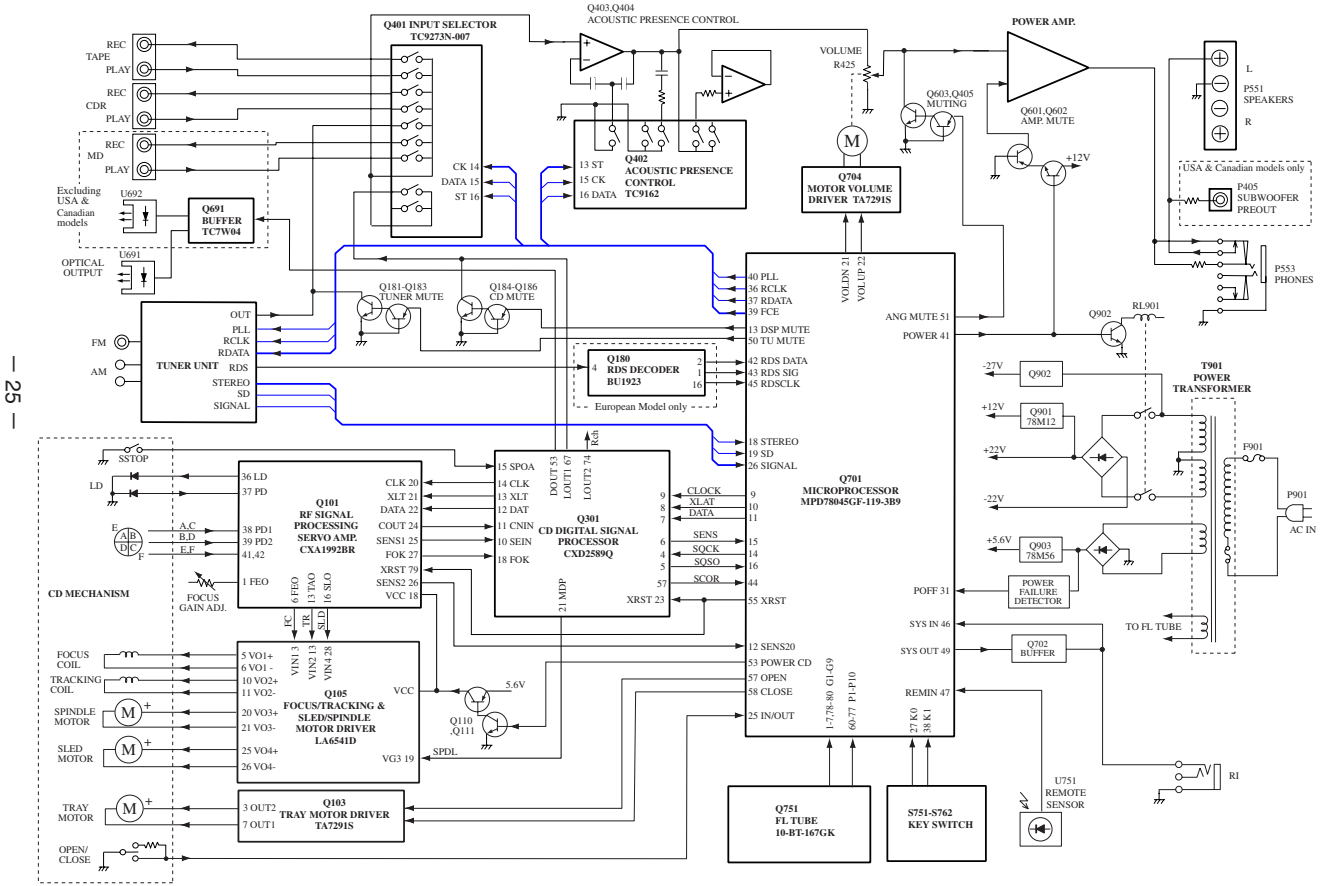

- 25 -

CR-305X
CR-305X

WIRING VIEW

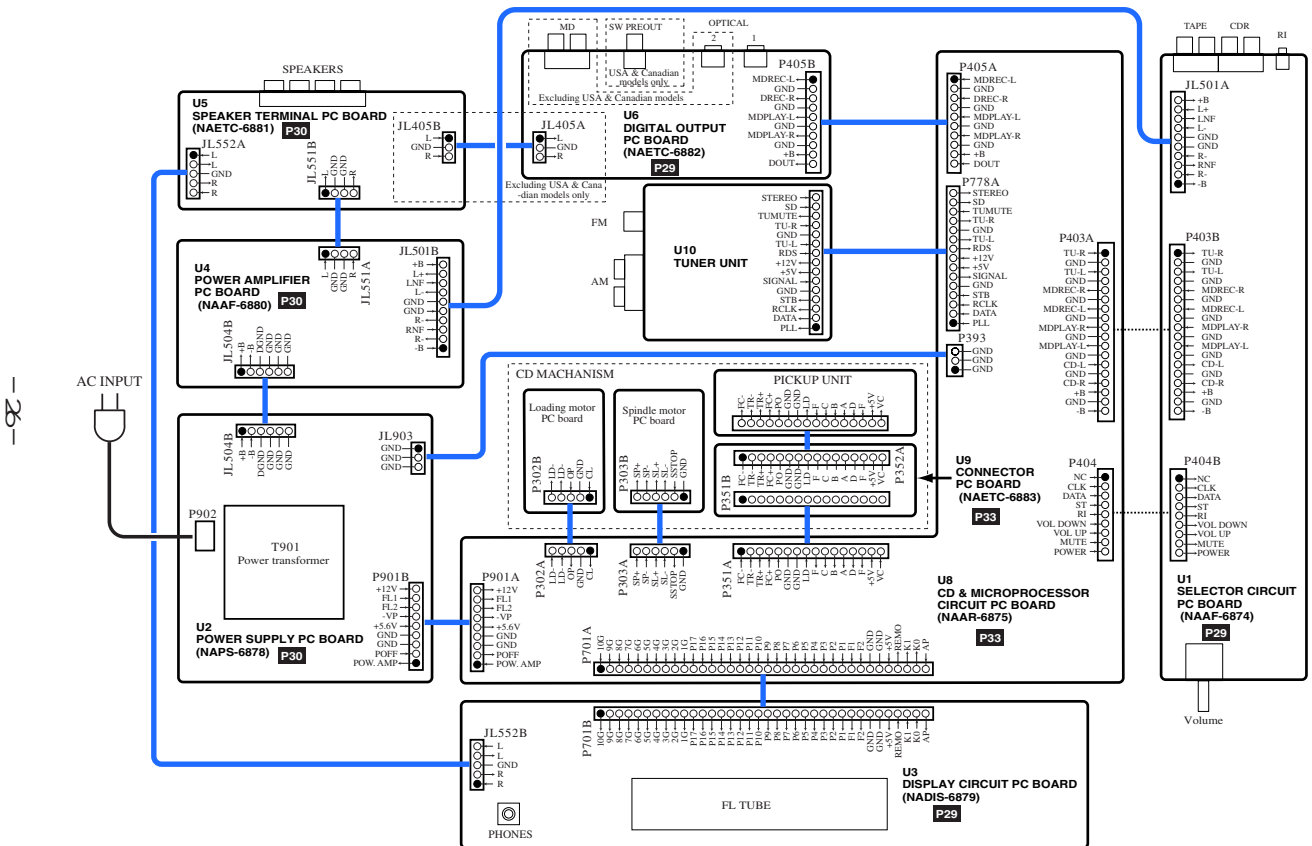

- 26 -

G

F

E

D

C

B

A

PRINTED CIRCUIT BOARD VIEW 1

U2 POWER SUPPLY PC BOARD (NAPS-6878)
Component side

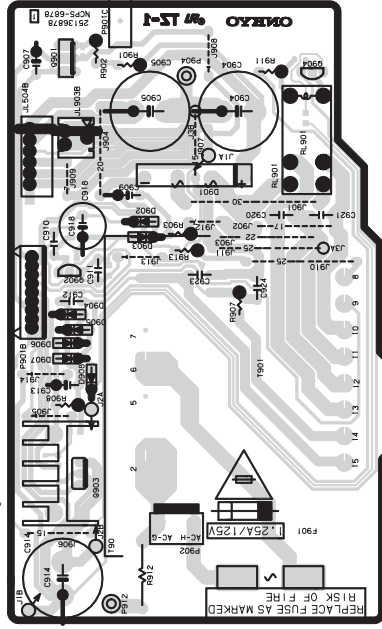

Soldering side

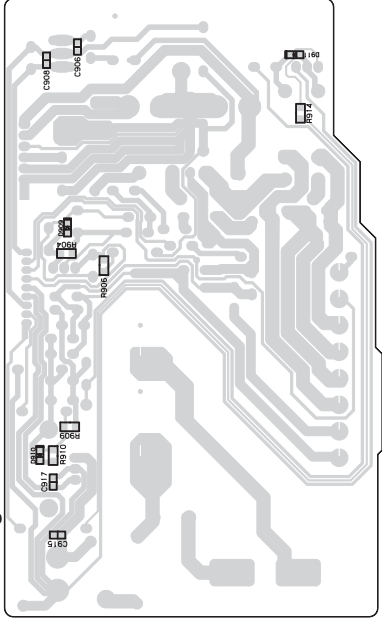

U1 SELECTOR CIRCUIT PC BOARD (NAAF-6874)
Component side

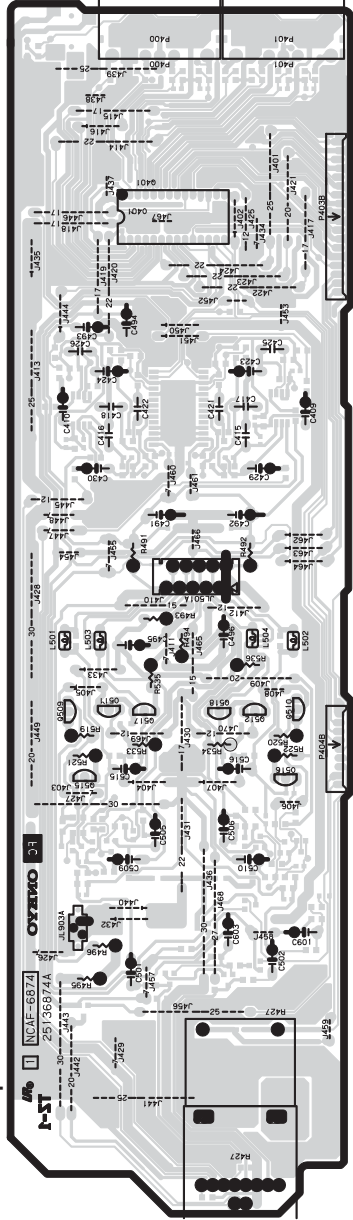

Soldering side

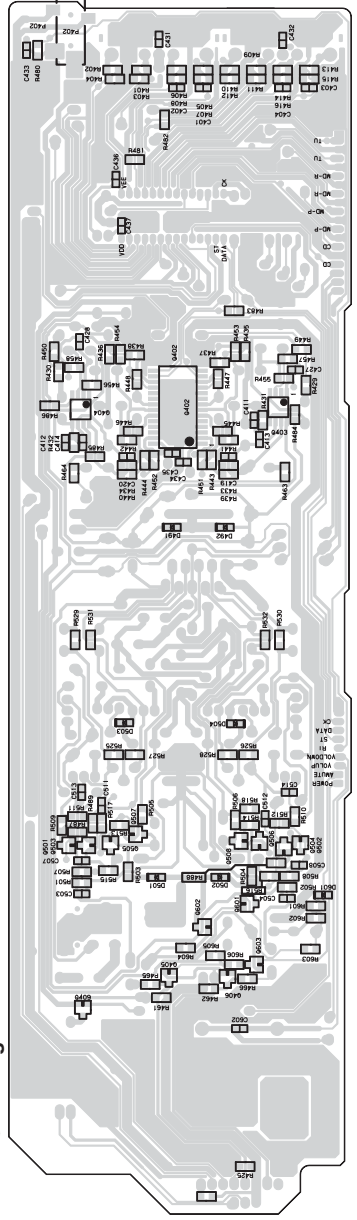

U5 SPEAKER TERMINAL PC BOARD (NAETC-6881)
Component side

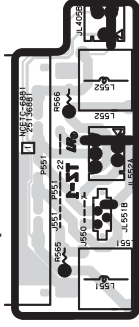

Soldering side

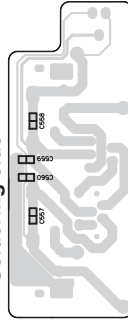

U6 DIGITAL OUTPUT PC BOARD (NAETC6882)
Component side

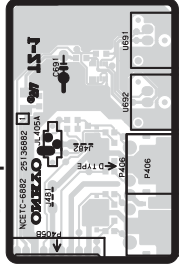

Soldering side

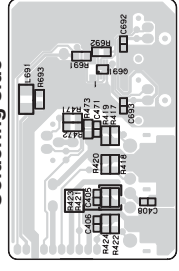

SCHEMATIC DIAGRAM (CD & MICROPROCESSOR SECTION)

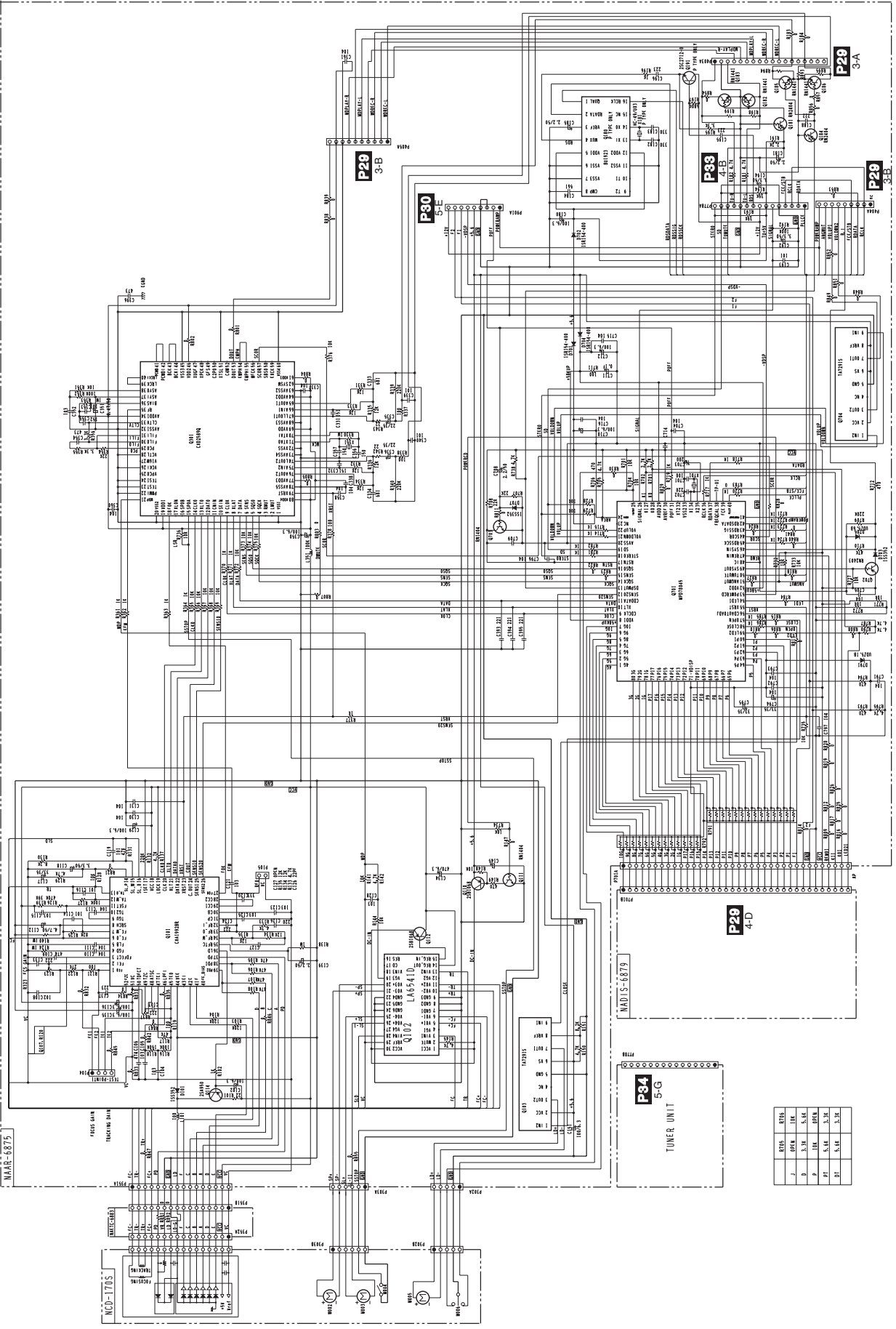

MAAR-6879

MAD1S-6879

TUNER UNIT

RELAY	DATA	STATUS
J	DATA	OK
D	3.3K	5.1K
P	10K	100K
PT	5.1K	5.1K
DT	5.1K	5.1K

A B C D E F G

PRINTED CIRCUIT BOARD VIEW 2

U3 DISPLAY CIRCUIT PC BOARD (NADIS-6879)
Component side

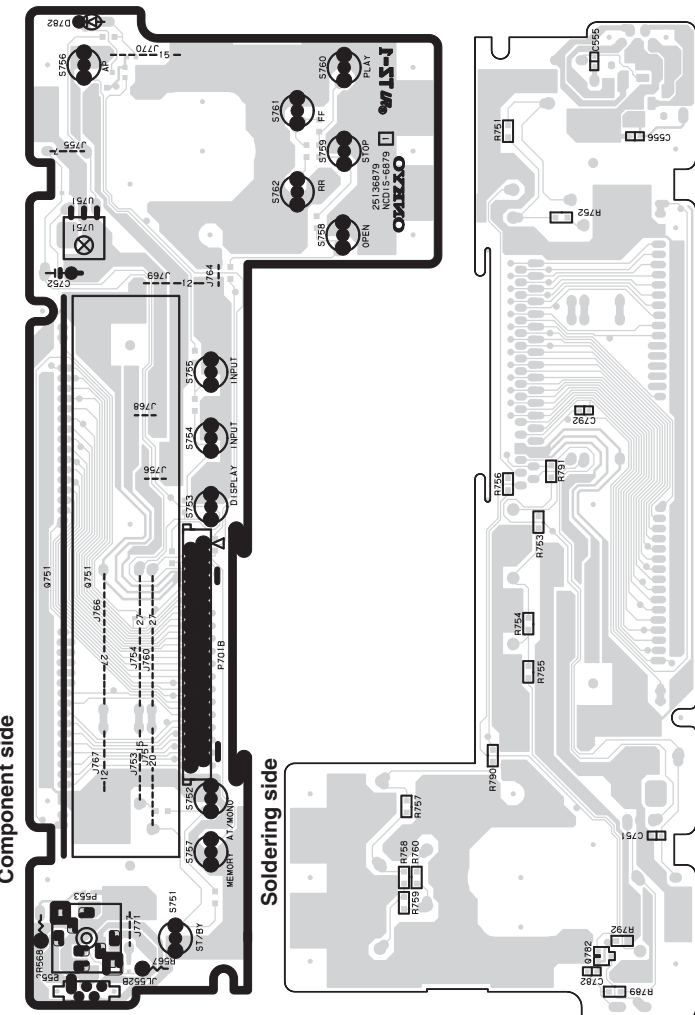

U8 CD CIRCUIT PC BOARD (NAAR-6875)
Component side

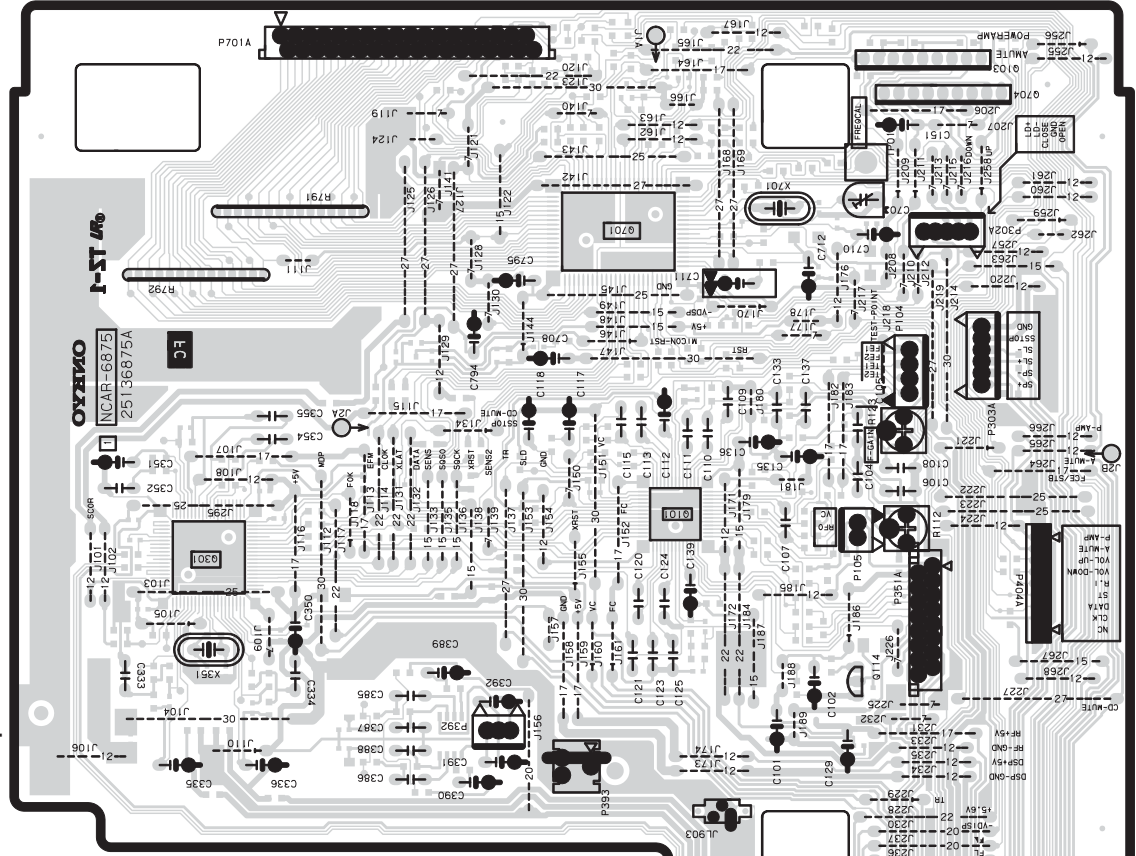

ASSEMBLING OF PAD

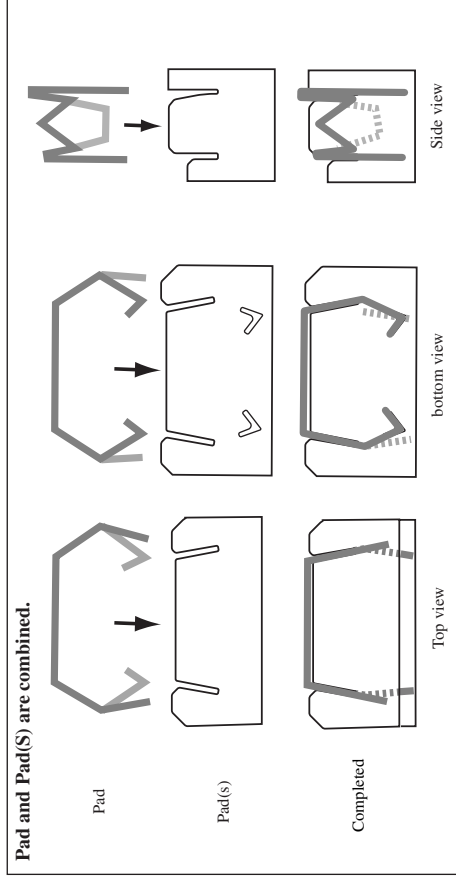
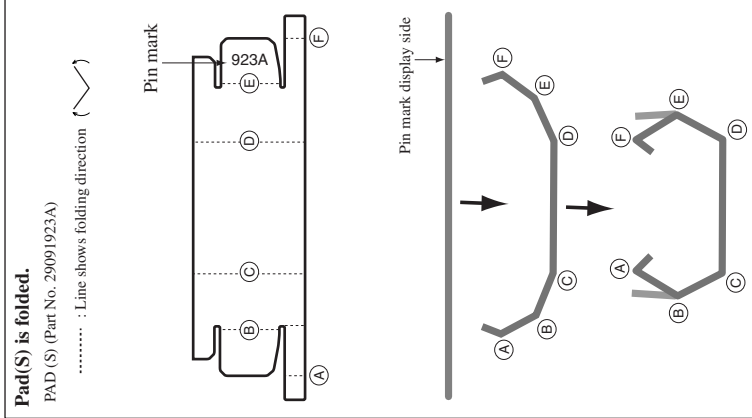
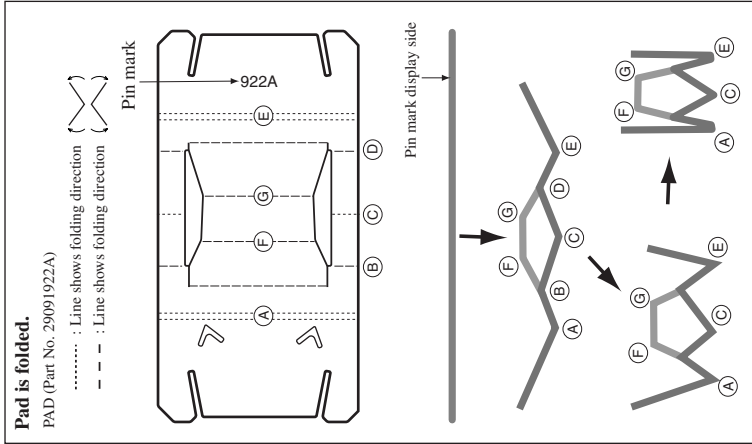

PACKING VIEW

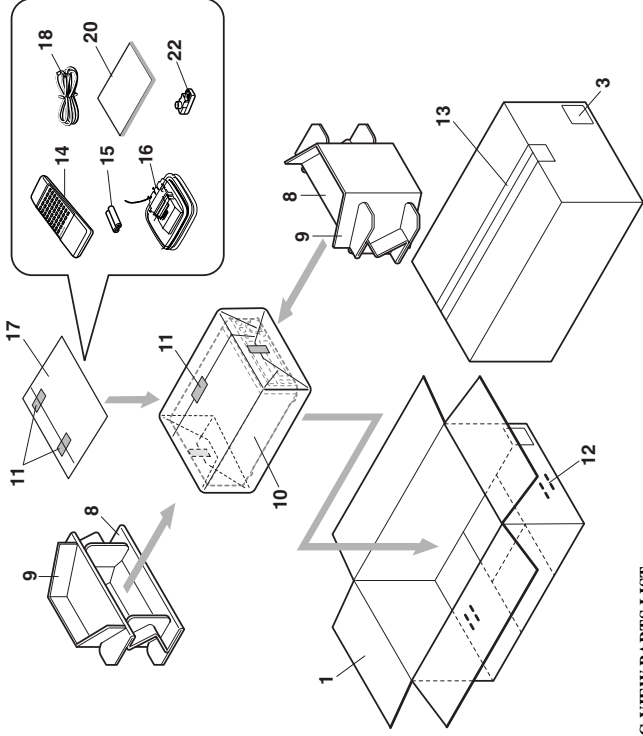

PACKING VIEW PARTS LIST

REF.NO.	PART NO.	DESCRIPTION	REF.NO.	PART NO.	DESCRIPTION
1	29053603B	Carton box<D,DT,GT>	17	29100897-1A	Poly bag 350*250
2	29053649A	Carton box<GR>	18	292142	FM antenna<D>
3	29053604B	Carton box<P>	20	29342905	Instruction manual U3FSI<P>
4	29362647	Label LUPC<D>	22	25065462	YAE21-0237, Antenna adapter<GR,GT,DT>
5	29362646	Label EAN<GR,GT,DT>			
6	29091922A	Pad (S)			
7	29091923A	Sheet 0.515*630*550			
8	29110149	Tape			
9	282301	Staple			
10	29110141	PP Tape			
11	24140421	RC-421S, Remote controller			
12	3010054	Battery, UM-L3			
13	232140	NMA-3057, AM Loop antenna			

NOTE : <D> : USA & Canadian models
 <DT> : Taiwanese model only
 <P> : European model only
 <GR> : Chinese model only
 <GT> : Asian model only

ONKYO CORPORATION

Sales & Product Planning Div. : 2-1, Nissin-cho, Neyagawa-shi, OSAKA 572-8540, JAPAN
 Tel: 072-831-8111 Fax: 072-833-5222

ONKYO U.S.A. CORPORATION
 200 Williams Drive, Ramsey, N.J. 07446, U.S.A.
 Tel: 201-825-7950 Fax: 201-825-8150 E-mail: onkyo@onkyousa.com

ONKYO EUROPE ELECTRONICS GmbH
 Industriestrasse 20, 82110 Germering, GERMANY
 Tel: 089 84 93 20 Fax: 089 84 93 226 E-mail: info@onkyo.de

ONKYO CHINA LIMITED
 Units 2102-7, Metropolis Tower I, 223 Hing Fong Road, Kwai Chung,
 N.T., HONG KONG Tel: 852 2429 3118 Fax: 852 2428 9039

